

# SIP construction

## A useful pocket site guide



Technically supported by



Technical support for the STA pocket guide kindly provided by NHBC and LABC. This guidance is general in its scope: the project design specification, along with the NHBC Standards and/or LABC Warranty Technical Manual take priority, where adopted.

The Structural Timber Association (STA) gratefully acknowledges the input and financial support of the following companies.



The Structural Timber Association (STA) is the membership body which promotes the use of structural timber and hybrid forms of timber construction such as structural insulated panels (SIP) in buildings. As part of the drive to deliver sustainable materials and energy efficient buildings, the STA provides best practice guidance for its members. SIP construction is a clear leader in fabric first solutions, addressing today's building regulations for thermal and acoustic needs, as well as being flexible enough to accommodate future improvements in the building regulations.

*“As part of a nationwide campaign to further improve quality and workmanship, this SIP frame guide provides information on correct procedures in constructing domestic and commercial structures. It should be read in conjunction with all project-specific drawings and technical details. The golden rule is always... if in doubt, ask! We hope you find this guide useful.”*



## **Andrew Carpenter**

Chief Executive

Structural Timber Association

Further information visit the STA website

**[www.structuraltimber.co.uk](http://www.structuraltimber.co.uk)**



# Contents

	Page
Introduction	5
Using the guide	7
Coordination checklist	8
Build sequence - what to look for	10
Best practice advice notes:	21
- Substructure	22
- Sole plates	25
- Frame erection	35
- Roof structure	44
- Insulation	56
- Vapour control layer (VCL)	59
- Thermal efficiency and airtightness	62
- Dry lining	64
- Fire stops	65
- Cavity barriers	66
- Cavity barriers and fire stops at party walls	72
- Masonry cladding	74
- Supported cladding	79
- Installing services	84
- Differential movement	89
Summary	94
Reference documents and further reading	95



# Introduction

This is an STA guide book offering generic advice on the assembly of the SIP, timber frame, timber floors, roof components and follow on trades, such as dry lining and cladding. A successful project requires every trade in the construction process to deliver the right quality work for the project's design objectives. Good projects start with good designs, and a good design is one that is matched to the client's expectations, both in cost and performance.

STA member SIP panels are factory manufactured to standards which are third party audited. There are many different SIP product types, each with their own third party certification, presenting specific performance and construction details. The designer and constructor should consult the SIP company on specific details that may vary from this generic guide. This guidance concentrates on site work - the accuracy of which is a vital link in ensuring the success of our buildings.

This pocket book presents best practice site checks to deliver good build quality for low rise domestic and commercial SIP buildings. The structural method covered is for SIP buildings constructed using the platform frame method of construction, with SIP external wall panels, timber frame internal wall panels, timber floor joists and SIP roof panels.



The principles can be applied to other types and methods of timber buildings - such as pre-insulated and closed panel frame systems.

Of course, Health & Safety on the construction site is of significant importance. See the Structural Timber Association website for further information and Health & Safety guidance.

This guide is of use to:

- Project managers
- Frame erectors
- Site managers
- Site inspectors
- Trade trainers
- Building control surveyors

This guide provides:

- Information for the coordination of successful projects
- Design-to-site details
- The build sequence linked to a checklist of 'What to look for'
- Best practice guidance on the conceptual nature of principal details
- Reference papers and further reading.

# Using the guide

This guide is not a substitute for the drawings, specifications or standard details issued with your project.

This guide complements the specific project design and specification. With SIP panels, the third party certification will provide specific details that override the generic advice in this guide. Where differences occur, the project design should take precedence. This is assuming that the frame design has been undertaken by an STA member, where the competence of the STA design team is part of the membership quality process.

Persons using the guide should be familiar with construction terms and have access to additional, more detailed literature.

The information is divided by colour code as follows. Look out for the icons below within this guide.



Best practice, including typical details/approach.  
See pages 21 - 93



Defect warnings, giving a clear indication of what not to do, are highlighted in red



Checklists, providing summaries of what to do, are highlighted in green



# Coordination checklist

Use the checklists below to ensure successful completion of SIP projects. Reference papers and further reading is provided at the end of this guidance.



## **Contractor and design team checklist**

- Foundation drawings
- Architectural drawings
- M+E drawings
- SIP frame erection drawings
- SIP frame details
- NHBC Standards/Chapter 6.2/Certification/  
LABC technical manual as appropriate
- Finishes and material lists for insulation, lining and  
cladding the frame
- Fire safety plan



### **Frame erectors and contractors checklist**

- Agreed work scope and specification
- Communication and liaison agreement
- Risk assessments/method statements
- Health & Safety plan
- Site Safe policy/fire safety plan reviewed
- Erection programme/delivery plan
- Craneage plan/method statement
- Scaffolding plan and details



### **Frame erectors checklist**

- Material schedules
- Assembly drawings/foundation drawings
- Fixing schedules
- Erection sequence
- Site supervisors checklist
- Special instructions/assembly



# Build sequence - what to look for

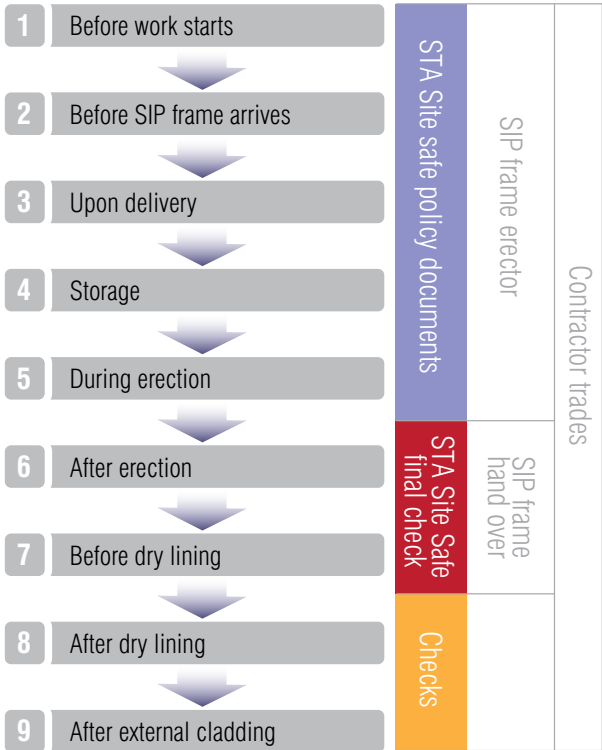

# 1

## 2 weeks before work starts

1. A full drawing package.
2. Detail booklet and erection instructions.
3. Nailing/screwing schedule.
4. Fire plan, Health & Safety plan and STA Site Safe correspondence.
5. Review plans, establish build methodology and check against standards.
6. Pre-start meeting completed.
7. Craneage and scaffolding agreed.
8. Agreed build programme.



# 2

## 1 week before frame delivery

9. CDM 2015 information provided - see STA Advice Note 9.
10. Top of substructure is level within tolerance.
11. Top of substructure is square and diagonals within tolerance.
12. Foundations are dimensionally correct.
13. Problems reported and rectified.
14. Scaffolding completed.
15. Access and plant off load available.
16. Crane hardstanding agreed.
17. Storage space available.
18. Check substructure against standards.



### 3

## Upon delivery

19. Check all components delivered.
20. Check for damage to frame.
21. Report shortages/damage.
22. Sign for goods received.



### 4

## Storage

23. Keep materials off ground, cover and maintain ventilation.
24. Store timber frame panels flat with sheathing side up.
25. Keep materials under cover but maintain ventilation.
26. If SIP panels do get wet ensure that they are allowed to dry before enclosing.

### 5

## During erection

27. Take care to avoid damage.
28. Follow drawings, details and standards.





29. Ensure temporary erection bracing is provided in accordance with STA guidelines (see member's H&S advice). Where tall wall panels are required, check with engineer if any special measures are required for temporary stability.
30. Check floors are not overloaded by materials. Report to frame engineer if damage found.
31. Ensure safe systems of work are implemented.
32. Flooring is protected or cleared of excessive moisture.
33. Check panels are correctly nailed and secured.
34. Plan work to be progressed systematically, floor-by-floor.
35. Tidy up as you go - see STA 16 Steps.
36. Complete work per floor level (do not drop back later).
37. Ensure scaffolding progresses well ahead and safely (do not modify without authority).

## 6

## Upon completion of erection

### What to check for generally

38. Frame is anchored to slab.
39. All damage is repaired.
40. Check external cladding and cavity width requirements - cross reference to the design drawings.



41. Check that the structure is wind and weathertight i.e. the breather membrane is fully wrapped around the building. Flashing and cavity trays are installed and lapped correctly with the breather membrane. Windows and doors fitted prior to commencing internal work.
42. Structural shell is handed over and signed for, complete with Site Safe letters.

### **Wall construction to check**

43. DPCs are under all ground floor walls in contact with slab.
44. Cavities are clear and properly ventilated.
45. Panels are the right way around, so that stud groups or posts are in the correct location.
46. All joints are aligned and tight to tolerance.
47. All fixings as per schedule/specification.
48. Breather membrane laps are present and repaired, if necessary.
49. Under beam loads check for SIP spreader rail or post.
50. Partitions are plumb and square.
51. Vertical DPCs are fitted to all external openings.
52. Locating plate and headbinders fitted.
53. Compartment wall straps fitted to internal timber frame wall leaves per storey height, as close to floor and ceiling diaphragm as possible at minimum 1200mm centres or as fixing schedule.
54. External ground levels are at least 75-150mm below the lowest timber level. Less than 150mm requires drainage details.



## Floor construction to check

55. Flooring is protected or cleared of excessive moisture.
56. Joists are in accordance with design drawings, with decking correctly screwed or nailed to them. Do not rely on adhesive alone.
57. Joists have adequate bearing, cross reference to the design drawings. Typically minimum 45mm, but some joist hangers and support conditions may require more.
58. Open web joists are braced using strongbacks and noggins are installed above and below partitions. Cross reference to the design drawings.
59. Joist connections are nailed and tight as per design.
60. Joists are level and even.
61. Stair is trimmed correctly with fixings to the design.
62. Engineered timber joists are not to be modified or notched. If there is a clash then ask.
63. Joist hangers are fully nailed and close fitting. Check joist hanger bearing and size compliance - do not use oversized hangers.
64. No excessive loads are applied to the floor, for example dry lining board stacks.



65. Timber packing plates are installed over walls between the top chords of top chord supported open web joists. Refer to drawing.

## **SIP roof construction to check**

66. Profiled timber wallplates or headbinders, if required, are fixed into the SIP wall panels and onto purlins in accordance with the fixing schedule to resist uplift.
67. Roof panels are prevented from sliding down the roof in the temporary condition prior to final fixing.
68. Final fixings are installed in accordance with fixing schedule to resist sliding and uplift.
69. Where a tied roof is required, ensure that thrust blocks are fixed in accordance with fixing schedule.
70. Where valley purlins are designed to resist the thrust from a tied roof ensure that valley purlins are not subjected to out of balance loading prior to removal of temporary works.
71. Where parapet panels are required check that they are fixed in accordance with the fixing schedule.
72. Roof is watertight before starting internal work.



73. Spreader rails or posts are fitted to ensure the continuity of vertical load paths to foundations under concentrated loads.
74. Reinforcing timbers around rooflights, dormers and openings are installed correctly.
75. For pitched roofs, a breather membrane is fitted to the top of the SIP before the counter battens, to create a ventilation void of at least 50mm.
76. Flat roofs are not a common detail with SIP. If a flat SIP roof has been specified, check with manufacturer/designer that it is appropriate and that adequate provision for waterproofing and roof ventilation has been provided.
77. Where truss rafters or cut roofs are used, check that adequate cross ventilation is provided at eaves and ridge using vent ducts or breather membranes with third party accreditation.
78. Where omission has not been proven to justified fit VCL to the internal face of the SIP. Air barriers are not VCL. See the airtightness section on page 59.



**What to check for generally**

79. Frame moisture content is less than 20% and watertight before fixing and any additional (if specified) insulation and dry lining.
80. Cavity barriers are fitted to separating floors and walls.
81. Any additional insulation to internal and external walls is correctly fitted with no gaps.
82. If vapour control drylining is used, or the SIP supplier has an appropriate assessment, then the vapour control layer (VCL) can be omitted - see page 59.
83. If fitting polythene based vapour control layer check that:
  - It is the correct density
  - 100mm laps at all joints
  - It is fitted to warm side of insulation
  - Holes for services are neat, tidy and taped to specification
  - Splits, etc. are repaired
  - Check correct sealing around socket boxes
84. Vapour control layer or vapour control dry lining board is fitted to all external walls and laps to floor and roof junctions.



## Services to check

85. For services in internal timber frame walls, notching or drilling as per details.
86. Noggins/dwangs fitted as required.
87. Vapour control layer (VCL) fitted - or SIP supplier has appropriate assessment to omit the VCL - see page 59.
88. Insulation is still in place.
89. Check all service holes in vapour control layer are neat and tidy.
90. No timber contact with flues or chimneys. A suitable clearance air gap should be provided.
91. Services in separating walls are protected so they do not affect the sound/fire performance of these walls (e.g. by battening out).
92. Avoid services in separating walls if possible.
93. No cables except service tails are located in external cavities.
94. Surface-mounted voids are created for services against SIP walls.
95. All first fix services installed as drawings.



## 8

### After dry lining

96. Lining is fixed to manufacturer's instructions with nails or screws not overdriven.
97. Installation matched to standards.
98. All joints sealed with filler, tape or skim and jointing compound.



99. Roof is tiled to manufacturer's requirements.
100. Roof is correctly ventilated or a breather membrane is installed.
101. Cavity perpend vents are fitted and not blocked.
102. Wall ties (plus fixings) and nails/screws are stainless steel and fixed at correct centres to SIP company specifications.
103. Wall ties are sloping away from the SIP. They should be straight and not have collected mortar droppings.
104. Check cavity width. Cavity barriers should be correctly installed and completely close the cavity.
105. Settlement gaps are fitted, e.g. at eaves, sills, penetrations and verges and are filled with suitable compressible filler, such as impregnated foam tape.
106. Window and door apertures are sealed, using an impregnated foam tape for example - and where relevant cover strips used.





## Best practice advice notes

	Page
Substructure	22
Sole plates	25
Frame erection	35
Roof structure	44
Insulation	56
Vapour control layer (VCL)	59
Thermal efficiency and airtightness	62
Dry lining	64
Fire stops	65
Cavity barriers	66
Cavity barriers and fire stops at party walls	72
Masonry cladding	74
Supported cladding	79
Installing services	84
Differential movement	89





## Substructure



### Defect warning

Badly laid and inaccurate substructure is the single biggest problem faced on site by the timber frame erector.



Extreme care must be taken to rectify faults before the construction begins.

### Check dimensions

Measure diagonals. If they are equal, the base is square.

Acceptable deviation:

+/- 5mm up to 10m

+/- 10mm over 10m

Measure lengths of wall. They must be within +/- 10mm of the dimensions shown in the drawings.

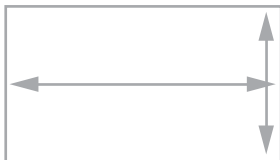

## Check edges

The edge must be within  $\pm 10\text{mm}$  of the straight measurement line.

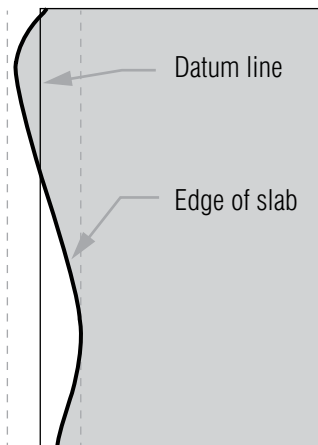

$\pm 10\text{mm max}$

## PLAN VIEW

## Check substructure level

Concrete slabs must be not more than  $\pm 5\text{mm}$  from datum. Over the whole slab, the level must not be out by more than  $10\text{mm}$ .

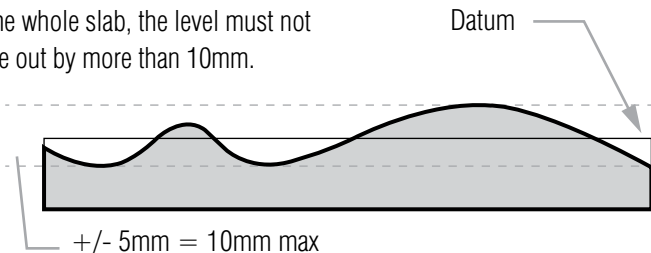



## Substructure cont.../

### Check levels of foundation walls

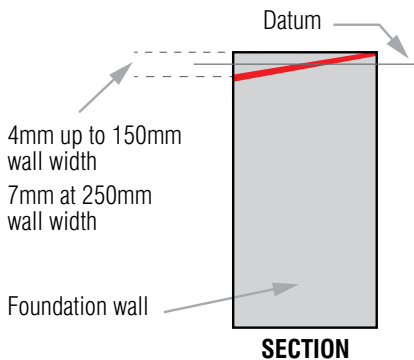
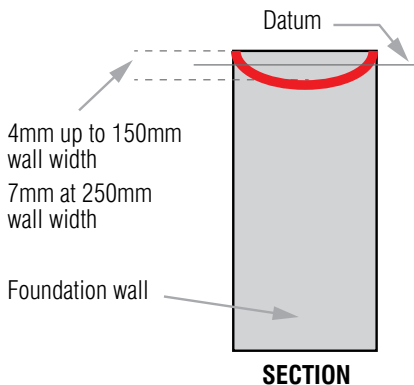

If you can't achieve the permitted tolerances, stop and consult.



## Sole plates

The sole plate is the first level of timber on a project. The tolerance of the setting out of the sole plate and its fixing can influence the complete building performance. It is therefore essential to **get this right**.

**Note:** Sole plates are sometimes called starter plates, locating plates or wall plates. The same principles apply at each storey lift level.



### Defect warning

Any faults at foundation stage only become exaggerated as each storey is erected.



If foundations are not within recommended tolerances, they must be rectified before panel erection starts. Errors cannot be rectified at a later stage.

Block upstands should not exceed 215mm - if the upstand appears unstable stop and ask.

Correctly set out the sole plate. For block up stands use a minimum 7.3N/mm<sup>2</sup> block.

Sole plates are usually installed before delivery of the timber frame.





## Sole plates cont.../

Soleplates should be positioned a minimum of 150mm above finished ground level. This may be reduced to a minimum of 75mm where additional drainage provisions are provided to the perimeter of the building. Refer to the Building Designer for details.

At accessible thresholds the landing should be designed with a gradient of between 1:60 and 1:40 to ensure water run-off and an adjacent drainage slot or channel provided to protect the entrance

### Typical level threshold detail

Diagram indicates typical threshold concepts which are to be agreed with the building designer per project.

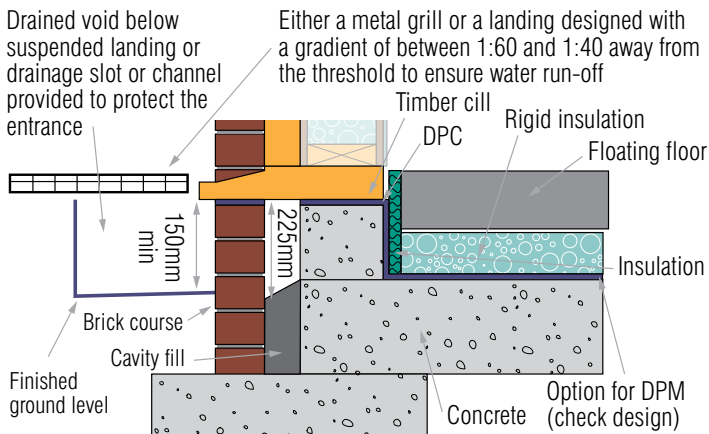



## Sole plate checklist

- Check DPC is provided under the sole plate to the specification
- Check size and grade of timber against specification
- Replace damaged plates or heavily fissured timber
- Sole plates are treated with preservatives. They are sometimes supplied in random lengths for cutting to suit on site or in pre-cut lengths. Cut ends to be brush treated with suitable preservative
- Check joints in the DPC lap by 100mm





## Sole plates cont.../

### Accuracy of setting out

The structural frame engineer is to be consulted if the sole plate extends or is set back by more than 10mm.

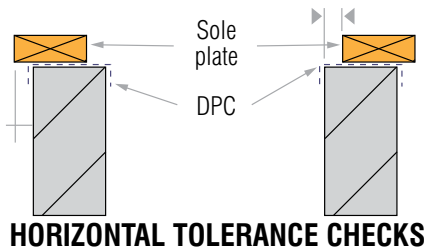

### HORIZONTAL TOLERANCE CHECKS

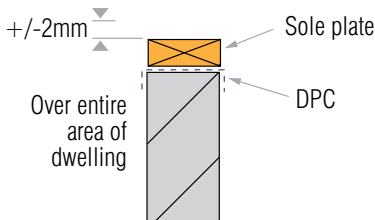

### VERTICAL TOLERANCE CHECKS

### Packing under sole plates

Where packing under a sole plate is required, the packing option to be adopted should be detailed on the construction drawings. There are three common options.



## Option 1

Temporary sole plate packing followed by permanent sole plate grouting.

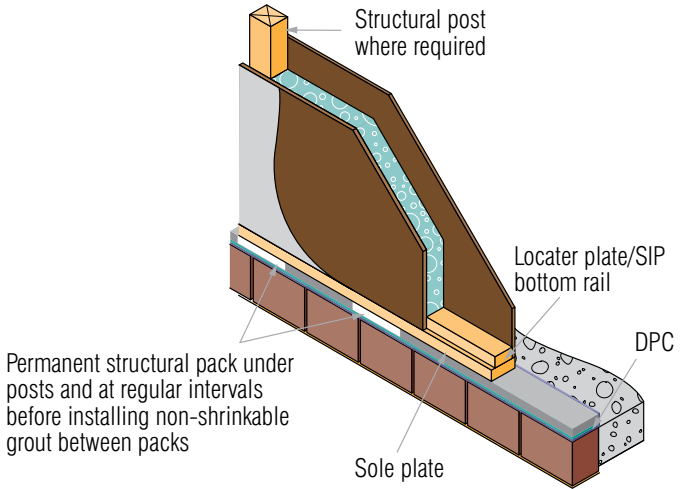

The sole plate is levelled on temporary spacers (no greater than 0.9m centres). After the ground floor SIP wall panels, with floor over or roof structure have been erected, then permanent packing is placed under the sole plates. This packing can be:

- Free flowing non-shrinkable grout along the full length and width of the sole plate
- Individual durable robust packers placed under the full area of each load point where relevant.





## Sole plates cont.../

### Option 2

Sole plate bedded on mortar levelling bed.

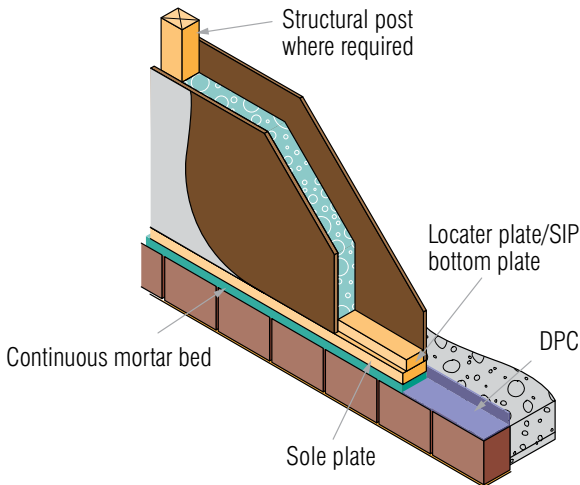

The sole plate is laid on a continuous level bed of mortar, prior to wall panel erection. The mortar should extend the full length and width of the sole plate.

The sole plate is checked for line and level and spacers may be used to do this.

### Option 3

Double sole plate 'sandwich'.

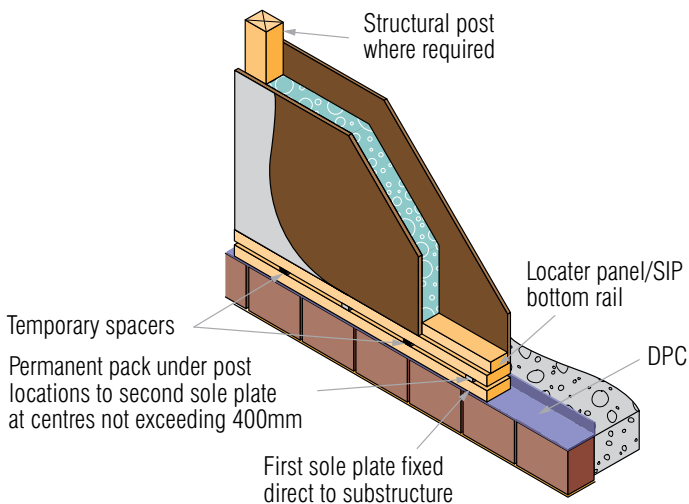

The lower sole plate is fixed along the contours of the supporting structure. The upper sole plate is fixed on top and levelled with temporary spacers inserted between the sole plates.

Once the first lift construction has been erected, permanent timber or robust packing is inserted for the full area.





## Sole plates cont.../

### Depth of packing

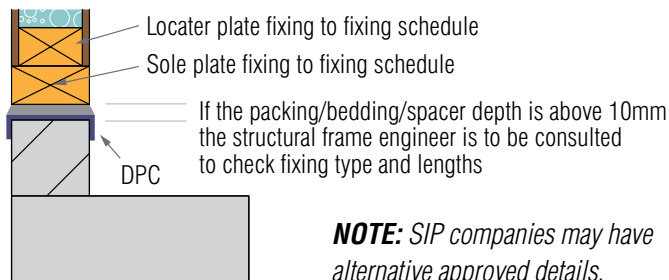

The packing/bed must:

- For the full area of the sole plate
- Be durable
- Not deform under load
- Maintain DPC between packing and plate.



### Defect warning

Consult design team about suitable fixing types matched to the packing and bedding depths.

### Fixing

The sole plate is to be anchored to the substructure to resist lateral, in-plane and vertical forces. The design drawings will provide the fixing method.

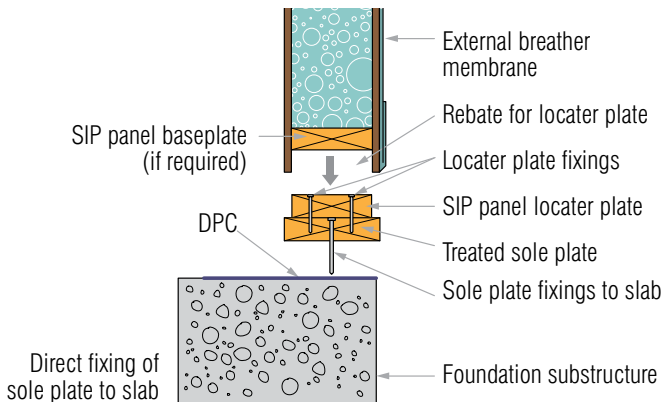

Direct fixing of sole plates using shot fired nails or screw and plug to design specification and centres.

Sole plate brackets within the internal envelope should be galvanised mild steel, minimum coating z275 with matching corrosion protection fixings.

If the fixing is in the cavity the brackets should be stainless steel.

**NOTE:** Fixings can be nails or screws to the SIP supplier design specification. In addition the SIP company may have specific sole plate approved details.





## Sole plates cont.../



### Defect warnings

Ensure fixing length takes account of packing depth. If in doubt, ask.

Avoid splitting the timber sole plates or damaging the substructure as this may cause the edges of masonry or slabs to spall. Should this occur, consult the design team.



### Fixing checklist

- Consult wall plate/sole plate layout
- Set out the wall plate/sole plate on prepared substructure
- Check line, level and diagonals before fixing
- Use the correct fixing method, at specified centres, as per fixing schedule
- Length of fixings and spacing to be agreed with frame engineer
- Brackets and fixings to be high load, galvanised coating or stainless steel nailed as specified
- Use non-compressing shims and durable packing



## Frame erection



Always check line, level and diagonals of substructure before erection. If they are not within the tolerances, do not start. Instead, consult site supervisor.

Ensure panels have been stored correctly - check damaged frames or out of square panels as these can cause the poor fitting frames and lead to out of tolerance buildings.

Fix locator plate to sole plate. Fixings should be at least 200mm centres. Locate SIP on locator plates and fix together - and to locator plate - as per the fixing schedule. There are two methods of jointing SIP wall panels together; using edge timbers or SIP splines. Panel fixings to edge timbers and splines should be at minimum 100mm centres on both faces of SIP. The frame specification should be followed in all cases. ***If there is no specification, ask for one.***

Nail or screw separate headplate into the rebate in the top of the SIP wall panels. Fixings should be at least 150mm centres on both faces of OSB panel into the locator plates and headplates. (A separate headbinder may also be required - refer to drawings). The fixing specification should be followed in all cases and ensure that binders cover the panel joints and overlap by 600mm.





## Frame erection cont.../

Check specification for VCL membranes to be installed during the panel erection, e.g. junction of internal to external walls and floor to external wall junctions. It should be noted that not all SIP products require a VCL. Consult the BBA certificate or design specification.

Check specification if sealant or compressible seal is used in the connections of panels and floors.

### SIP wall frame connection

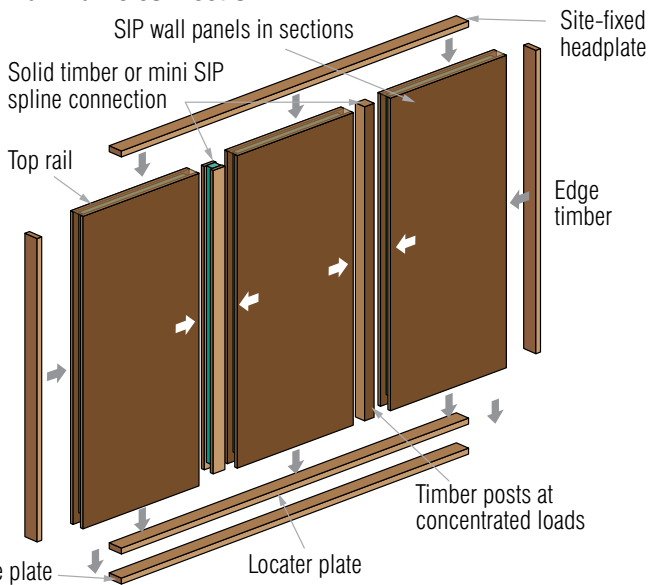



## Connection using edge timbers

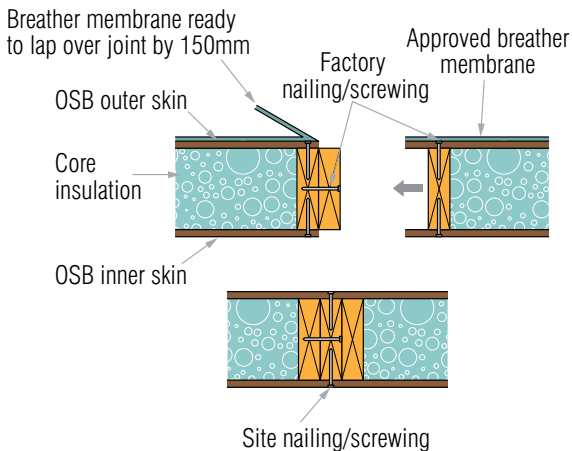

## Connection using mini SIP splines

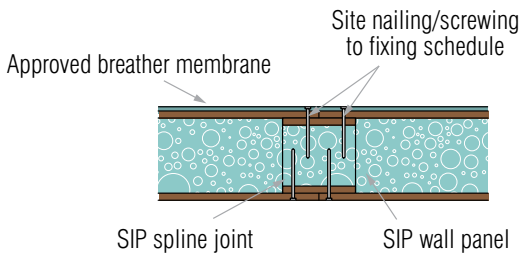



## Frame erection cont.../

### Typical floor zone detail; engineered floor joist \*

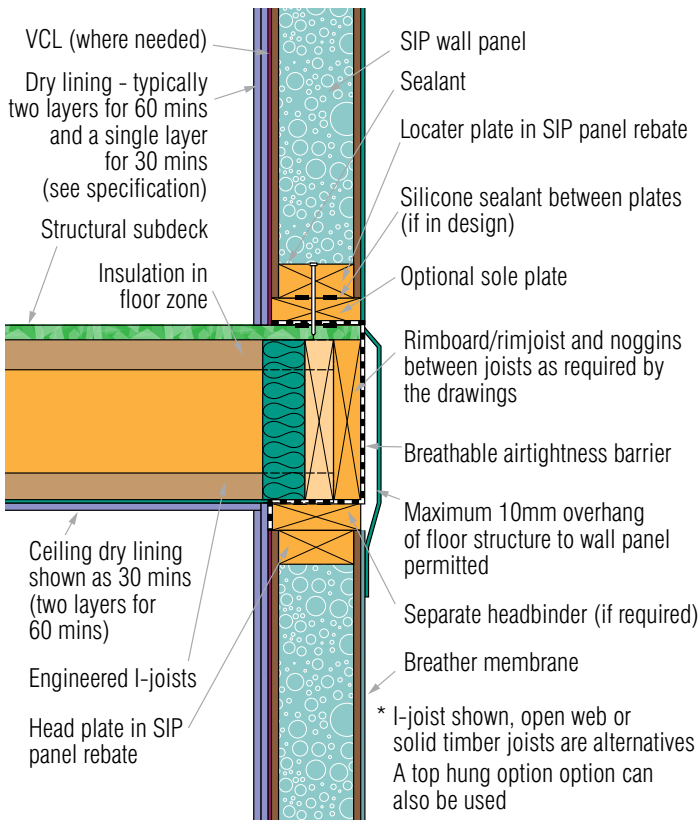

## Top hung joists

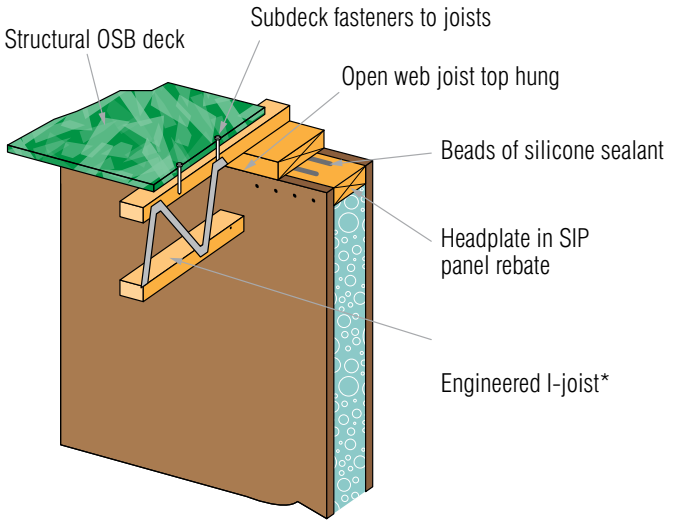

\*Open web shown; I-joist or solid wood joists are alternatives





## Frame erection cont.../

### Vertical Tolerances

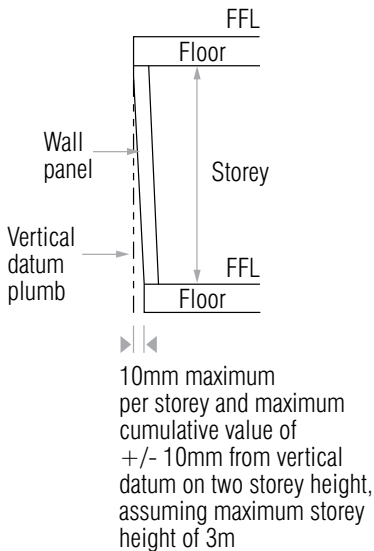

### Line of panels

$\pm 3$ mm on the line of the sole plate.

$\pm 5$ mm deviation measured at wall panel mid height from an agreed datum line.



Remember, the more accurate the plumb and alignment, the more constant the cavity width.

Tolerances differ for taller panels and should be by agreement with the designer.

## Alignment

Internal horizontal building face of the panel on plan shall be a maximum step of 5mm with an average of no more than 3mm to any one panel.

Steps to the vertical level shall be reviewed to consider the impact on floor or roof structure above the wall.

Gaps above 2mm in height and above 300mm long shall have a rigid full bearing packer inserted. Maximum steps shall be +/- 5mm before investigations are undertaken and adjustment works considered.

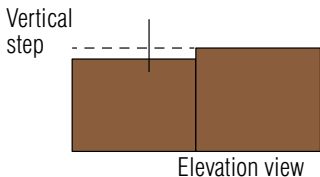
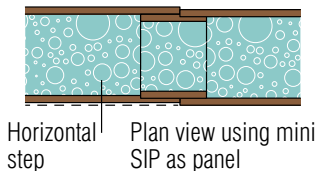
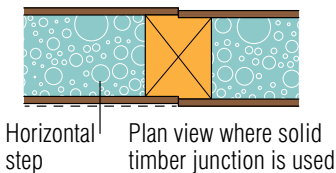

Aim for nil deviation and use the manufacturer's detail books and checklist.

Frame cannot be plumb after the dry lining board is fixed.





## Frame erection cont.../

### Non-loadbearing walls

Non-loadbearing walls on floor decking must be adequately supported on joists or noggins below. All non-loadbearing walls below the floor deck/joists require lateral restraint at the top rail/head binder at maximum 600mm centres. Check the design details for secure fixing.

### Breather membrane

Breather membrane is typically pre-fixed in the factory. Laps on the membrane to manufacturer's instructions: as a guide laps are usually 100mm horizontal; 150mm vertical; lap sole plate by 25mm.

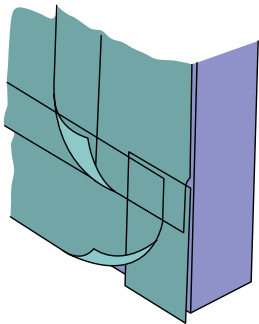

Repair damaged areas with surplus material lapped correctly below and over the existing material and securely stapled.

Make sure any membrane tears are properly repaired. None of the timber frame structure should be visible once the membrane is fixed and any tears made good.

## Patching tears in breather membrane

'Square-off' area to be patched  
and extend cuts to top by  
150mm as shown

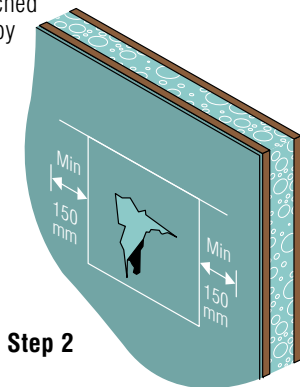
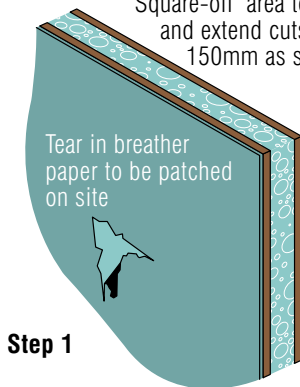

Slip breather paper  
patch up below site. Cut  
breather paper to provide  
100mm min over-lap,  
allow 150mm min over-lap  
to both sides. Allow 100mm  
min over-lap to bottom edge

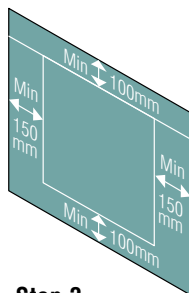

Staple in position using  
stainless steel staples at 150mm centres





## Roof structure

### Diagrammatic details for SIP roof members

The project should have expanded and detailed drawings and design available for these junctions. These diagrammatic details are for guidance only and indicate general construction details that should be considered.

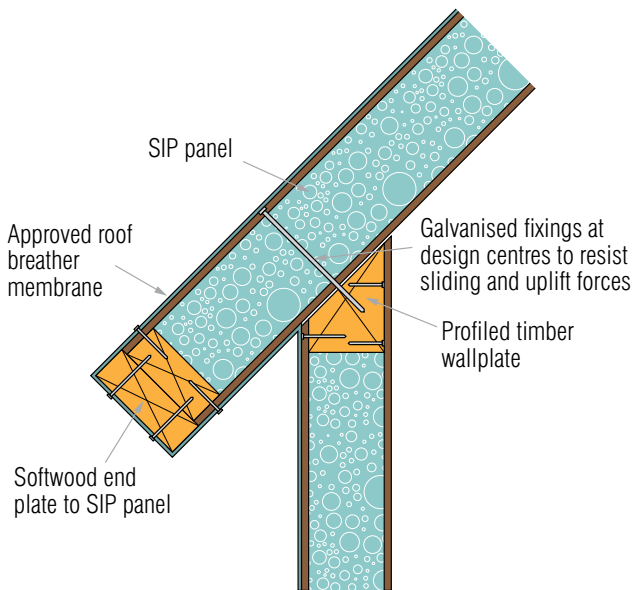



## Eaves to roof junction where SIP roof is adopted

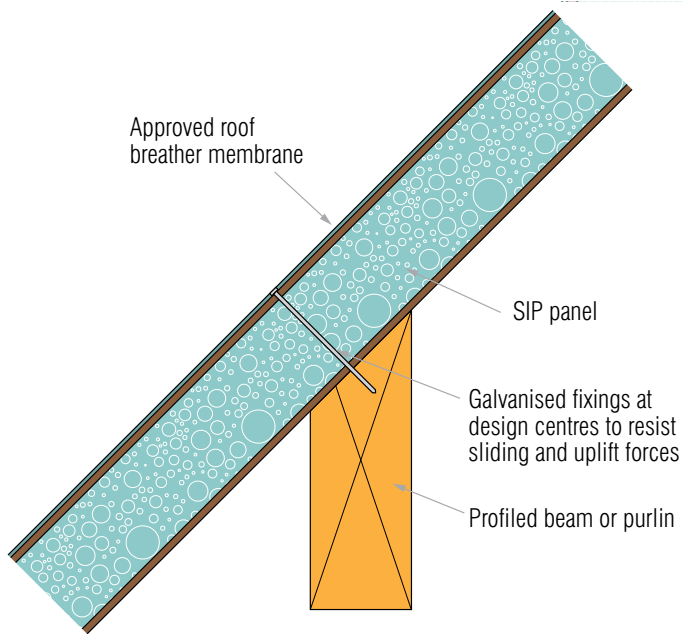

**Note:** Purlin can be a composite of several members to structural design.





### SIP roof at ridge purlin

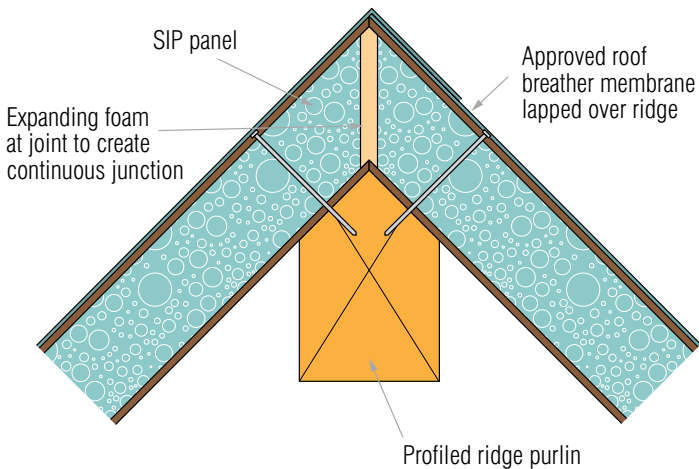

**Note:** Purlin can be a composite of several members to structural design.

## SIP ridge without ridge purlin - tied roof structure

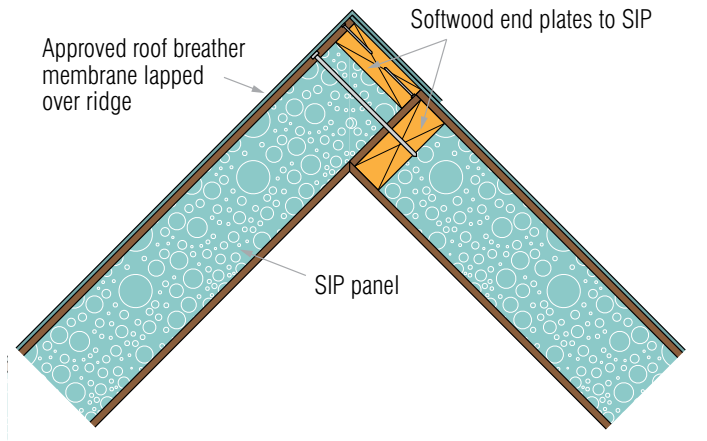

### Defect warning

This design results in thrust at wallplates. Resistance to thrust to be addressed in the design details - check with designer that ridge purlin is not required.





### Diagrammatic valley gutter

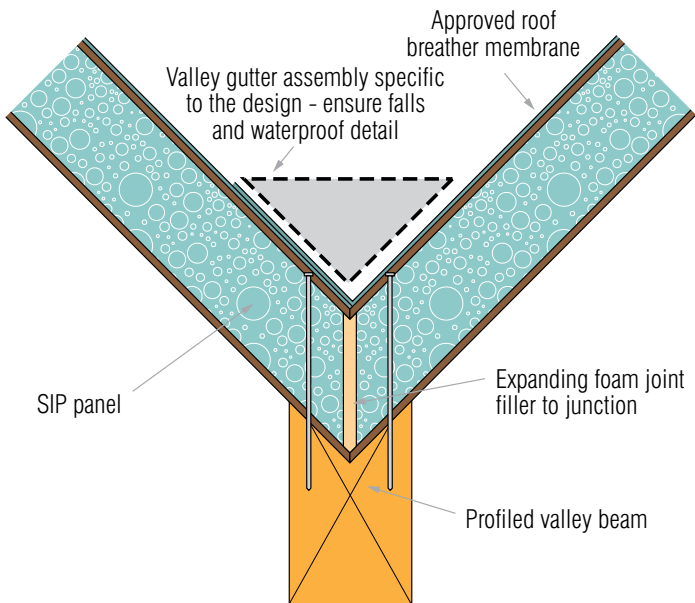

**Note:** Purlin can be a composite of several members to structural design.

## Parapet wall to sloping roof detail

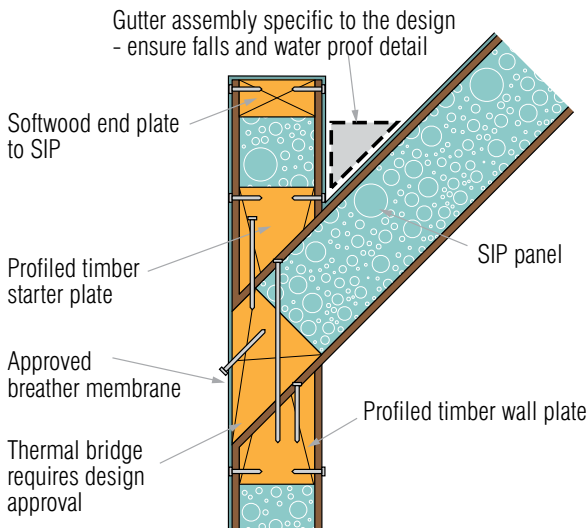

**Note:** If bevelled fillet pieces are used care must be taken to avoid splitting when nailing or screwing - fixings of suitable length are to be used so that they are embedded into the solid timber sections to provide adequate roof uplift resistance - consult the designer.





## Roof structure cont.../

### Diagrammatic roof to gable wall

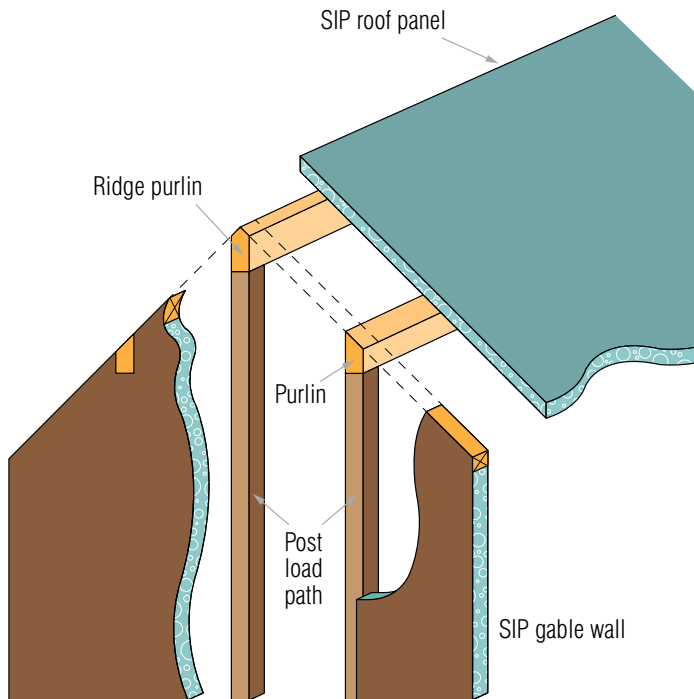

Alternative designs for low loads  
to spread over SIP panel

## Diagrammatic roof to gable wall with opening

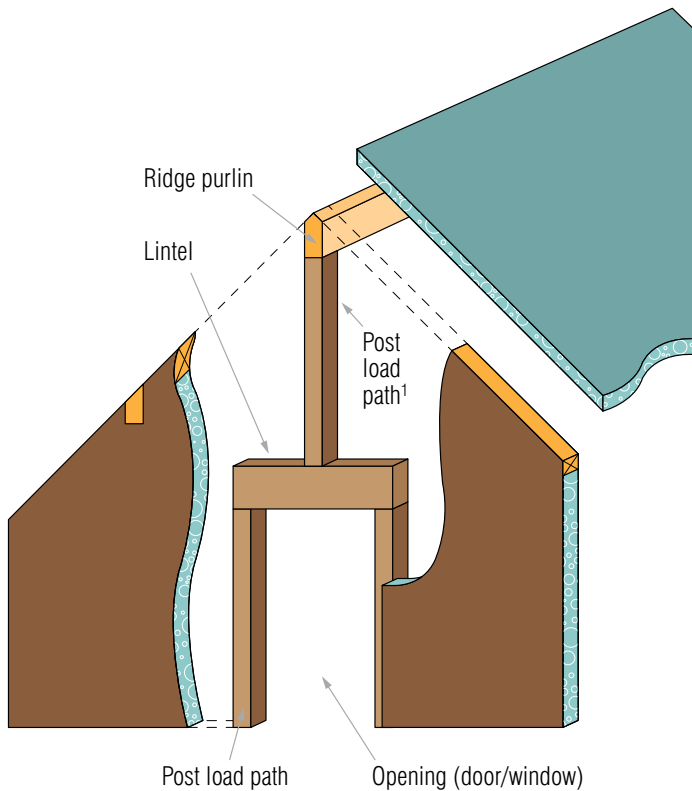

<sup>1</sup> Or by an engineered solution to spread the loads over the SIP panel





### Diagrammatic roof light

Specific watertightness and thermal/airtightness detailing needed.

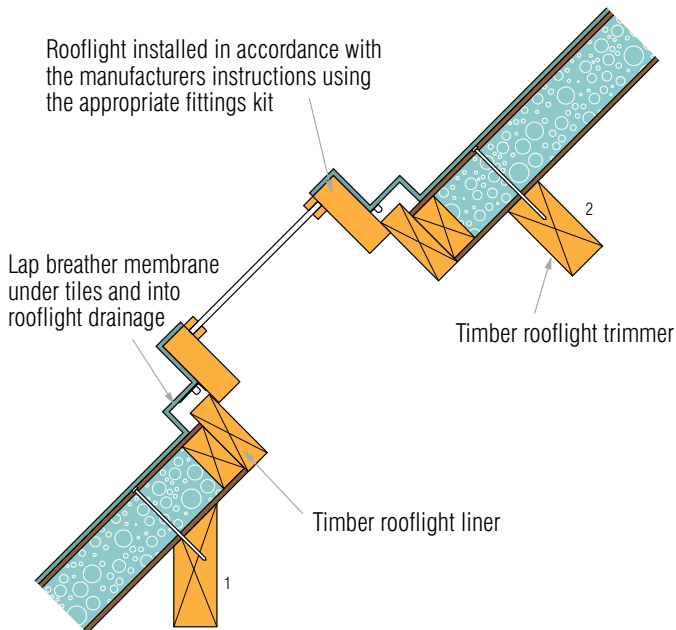

1 Vertical roof light trimmer to engineer's design

2 Canted purlins as alternative to engineer's design



## **Pitched roof construction - roof finishes**

Covering for pitched SIP roofs can be any type of covering that may be used on any other type of roof (e.g. tiles, slates, profiled metal etc). A ventilation void must be provided between the SIP and the roof covering, so the use of counter battens before tiling battens, profiled metal roofing or any other covering should be considered. Roofing battens should be fixed to the SIP roof with the use of screws.

Pitched SIP roofs will generally consist of the following layers:

- Tiling or slates
- Tiling battens
- Counter battens (providing a path for ventilation and water runoff)
- Breathable roofing membrane
- SIP of the required thickness
- Vapour control layer (if required)
- Battens forming a service void
- Internal lining





## Roof structure cont.../

Key points are:

- A breather membrane is fitted to the top of the SIP before the counter battens to create a ventilation void of at least 50mm.
- Adequate cross ventilation is provided at the eaves and ridge using vent ducts or breather membranes with third party accreditation.
- Ventilation is always provided between the roof covering and the SIP panels (cold roof construction).
- That a VCL or air barrier (if required) is fitted to the internal face of the SIP panels.
- To enable the tile batten spacing and fixing densities to be used as designed the fixing type must be exactly as specified by the designer

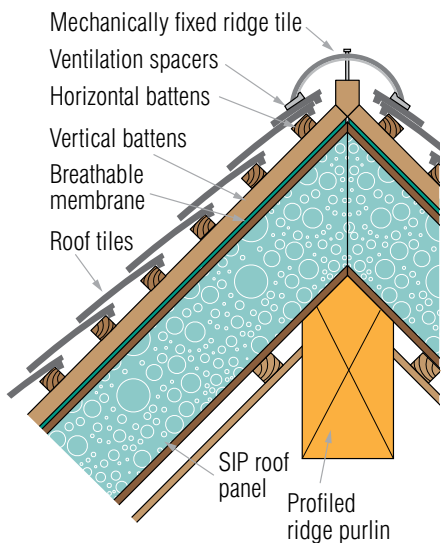

## SIP flat roofs - roof finishes

Zero degree pitched flat roofs are not recommended for any construction and a fall is required to be agreed with the designer. Any reference to flat roofs assumes a nominal pitch.

SIP flat roofs are classified as cold flat roofs, and spans may ultimately be limited by requirements for ventilation. The SIP roof should be overlaid with battens or tapered firrings to maintain the required ventilation void, and then overlaid with a deck and roof covering.

Flat SIP roofs will generally consist of the following layers:

- Waterproof roofing membrane
- Plywood or similar roof decking
- Firrings to form a runoff and create a ventilation void
- Breathable roofing membrane
- SIP of the required thickness
- Vapour control layer (if required)
- Battens forming a service void
- Internal lining

### SIP cold flat roof

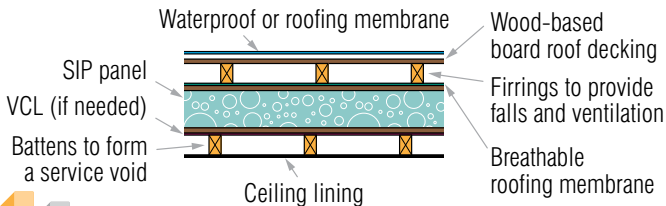



## Insulation

Site applied insulation is not necessary for SIP walls or roofs, since the insulation is an integral part of the panel. However there are some situations in SIP buildings where site applied insulation may be required.

### Trussed rafter roofs

For trussed rafter roofs, it is common practice to have insulation at the ceiling tie level. This is called a cold roof space. Other roof types are available and the design specification should be consulted for guidance.

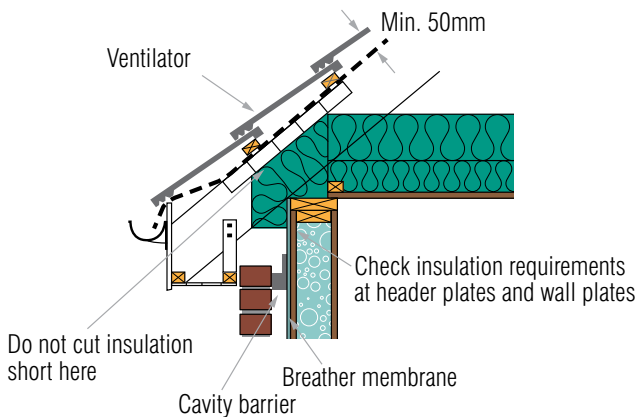



### **Insulation in trussed rafter roofs checklist**

- Ensure roof insulation is placed below ceiling wind bracing
- Ensure insulation is dressed around and over but not beneath water tanks
- Cross-lap insulation in layers for roof insulation to required depth
- For a ventilated roof, rafter ventilator must be fixed to stop insulation from blocking airflow
- Insulation must continue over and below the wall head to prevent cold bridging

### **Fully filled party walls - standard timber frame option**

Fully filled insulation to party walls is a common requirement for current building regulation compliant buildings. Check if project requires fully filled insulation. See STA Advice Note on party wall insulation.

Insulation between timber frame; mineral wool or to design specification.

For open timber frame panels, insulation between timber frame panels installed once the building is dry and watertight.





## Insulation cont.../

For sheathed party walls check method statement to install insulation between timber frame panels so that insulation is installed and kept dry.

Refer to STA Advice Note no. 10 - Party Walls for further information.

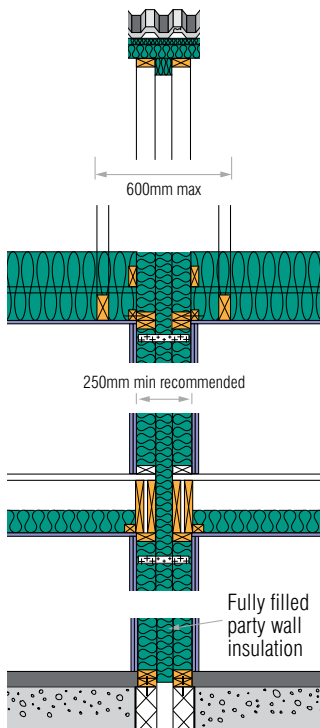

### Defect warning

For the party wall cavity check there is a minimum 50mm clear gap and the distance between the internal faces or dry lining board is a minimum of 240mm.



## Vapour control layer (VCL)

Durability of the structure is ensured by keeping the timber dry. In most SIP constructions, this is achieved through a combination of:

- A vented cavity between the SIP wall panels and the external cladding.
- A protective breather membrane on the cold side of the insulation - applied to the outer face of the sheathing.
- A vapour control layer (VCL) from inside to outside for which BS 52520:2011 can be used to determine if an additional VCL is required, or if the SIP panel can inherently provide an effective VCL.

### **Airtightness**

It should be noted that the VCL layer can be an important component in providing airtightness. The design specification should be consulted for airtight details.

In addition to the designer being consulted, checks should be made to ensure that air circulation and ventilation is included in the airtightness levels of the build.

Air barriers are not VCL and where needed can be inside or outside, or indeed part of the SIP panel boarding.





## Vapour control layer (VCL) cont.../

Check the design requirements and/or with the SIP company if an airtight barrier is required.



### Dry lining and VCL options for walls

Batten method

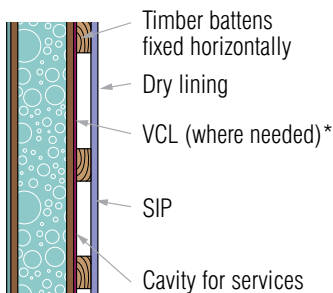

Direct method

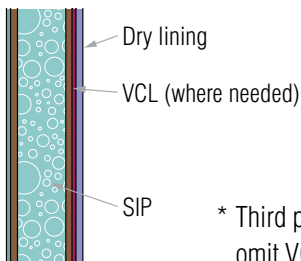

\* Third party checks can omit VCL - see page 59





## VCL checklist

- ❑ A VCL is on the warm side of the insulation, applied directly on the SIP face
- ❑ VCL may be a separate polythene sheet or a vapour check dry lining board or appropriate internal wood based board, or BS5250 third party approved VCL to be inherent in the SIP
- ❑ Do not install VCL if moisture content of framing is above 20%
- ❑ For 500 gauge/125 micron polythene sheet VCL lap 100mm with joint. Fix with 9mm by 9mm by 18 gauge stainless steel staples at max 250mm centres
- ❑ Airtightness specification may require specialist VCL tape. Consult with the design specification
- ❑ Sheet VCLs to overlap into separating walls and across to floor VCL (airtight barrier). Return VCL into reveals, head and sill of openings. Consult with design specialist
- ❑ Repair damaged VCL to ensure airtight and vapour control is maintained. Seek advice on repairs





## Thermal efficiency and airtightness

New SIP buildings have high levels of insulation, double glazed windows and highly efficient heating systems. To ensure that the design matches the as-built performance, the site trades are to be aware of the accuracy of the construction and to apply the design details.



If the detail is not considered practicable, then consult with the design team - do not change the design intent.

Check with the Building Designer that suitable background ventilation is provided for projects that have strict airtightness requirements

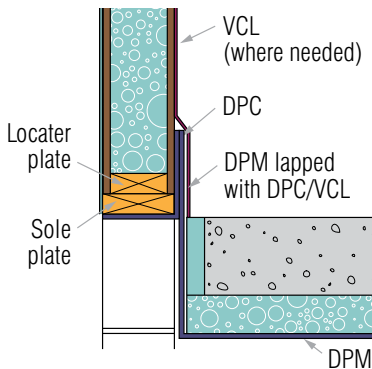

Continuity of the airtightness barrier is important, especially around windows, doors and other penetrations through the external envelope.

At floor level, make sure the VCL (where needed) laps with the DPC.

Make sure that the VCL around the floor frame, if needed, will be able to lap onto the VCL for the walls.

The airtight layer around the floor should be of a suitable material to ensure that no water vapour collects at this point. E.g. do not use polythene, but a breathable airtight membrane.

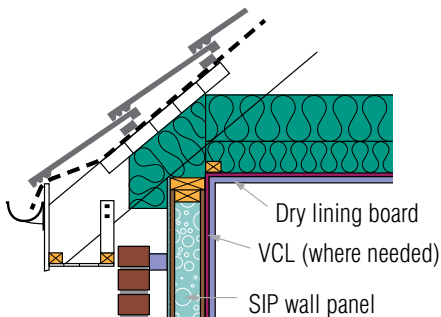
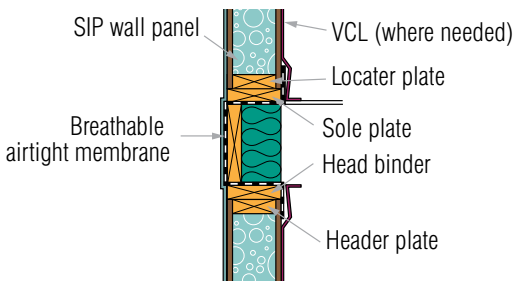

Ensure the VCL around the wall to the roof laps, or where a SIP with an inherent VCL has been agreed, then junctions are suitably sealed.





## Dry lining

Dry lining should not occur until the frame is watertight. Test services in wall before dry lining.



Dry lining is used for final wall finish providing fire protection and acoustic performance. Fixing of dry lining should not occur on timber framing with greater than 20% moisture content or damp/wet OSB SIP boards.

Correct fixing of the dry lining is essential to achieve the design fire performance. If the fixings are inadequate the boards will fail early.

Where the fire resistance is achieved with two layers of board, both layers should be fully nailed or screwed to specification.

Fixing specifications depend upon type of fixing used - board nails or drywall screws. Always refer to manufacturer's instructions.

In general, nail fixings should be at maximum 150mm centres and drywall screw fixings at 230mm for ceilings or 300mm for walls.

Drywall screws reduce the risk of 'nail popping' in walls and ceilings, resulting from moisture movement in the timber. Ensure the board is fixed tight to the timber support.

Cement boards are appropriate for use in rooms where high moisture content may be present or where tile hanging is required.



## Fire stops

Fire stops are used to ensure that fire resistance requirements are met for the compartment of the building. Typically they are non-combustible board or mineral wool - proprietary systems are also available.

Fire stops are installed at:

- Wall junctions between dwellings such as roof to wall.
- Where services and penetrations occur at external walls and floors.
- Other fire compartment separations.

Typical fire stop locations

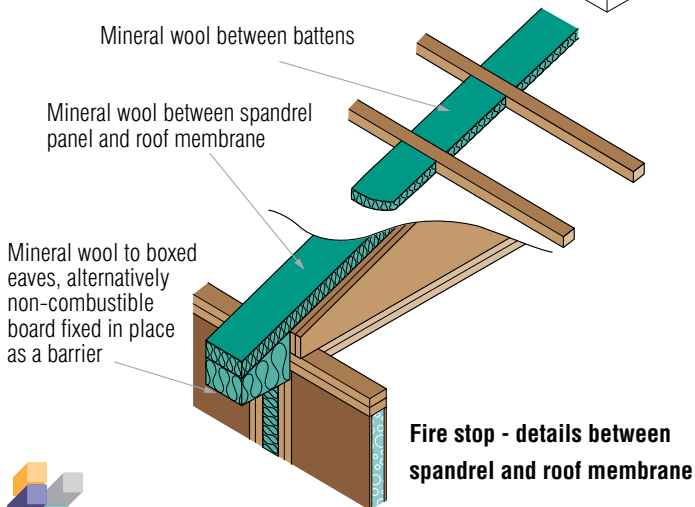
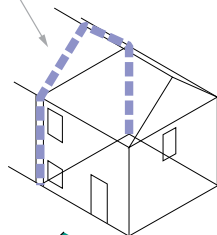



## Cavity barriers

Cavity barriers are used within cavities to prevent the spread of smoke and fire. They can be rigid - preservative treated timber battens, non-combustible board - or flexible and based on mineral wool or approved intumescent-based strips.



Cavity barriers must be fixed accurately in all positions shown on drawings and to the appropriate material specification.

All floor and party wall cavity barriers to be positioned against solid timber members e.g. studs, rim beam.

If you are in any doubt about the positions, please ask.

For dwellings, cavity barriers are required:

1. Around all openings and penetrations in external walls.
2. The top of the external wall cavity.
3. The junction between compartment walls or floors and external walls.
4. At the junction between a compartment wall that separates buildings.
5. For non-domestic properties in England and Wales vertical cavity barriers are required at every 10m.

## Cavity barriers at penetrations through external wall

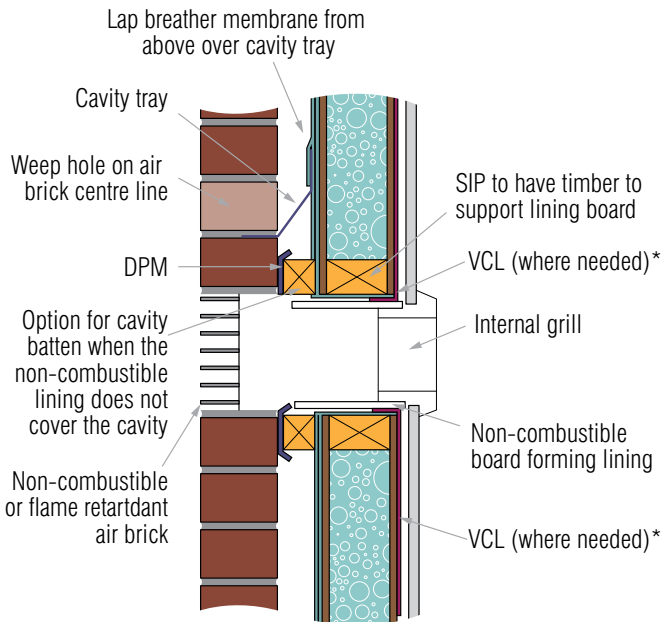

\* Third party checks and omit VCL - see page 59





## Cavity barriers cont.../

In **Scotland** and **Northern Ireland** cavity barriers are also required:

1. At the junction between any floor and an external wall.
2. At vertical or horizontal centres not exceeding:
  - a) 10m in Scotland.
  - b) 8m in Northern Ireland.

See STA guide on installing cavity barriers.

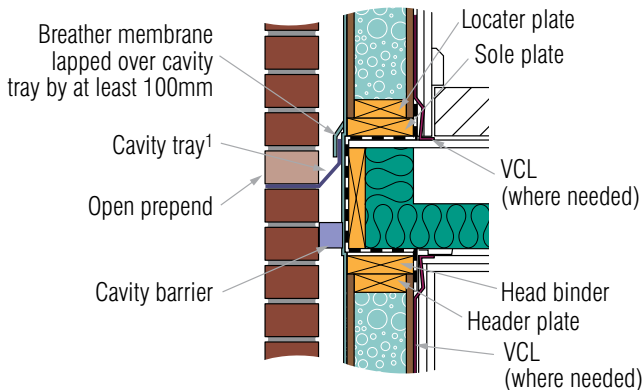

**NOTE:** Top hung detail is an alternative

External wall details where cavity barriers are required - see below.

<sup>1</sup> Check if cavity tray is already part of the cavity barrier assembly.



## Cavity barrier position

The diagrams indicate cavity barrier positions for a typical semi-detached or end terrace dwelling. Full details of positions of all cavity barriers and fire stops will be found on the design drawings. For fixing requirements, refer to specification.

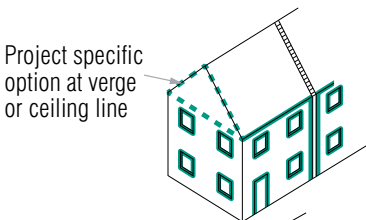

### England and Wales cavity barriers for a house

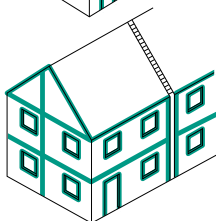

### Scotland and Northern Ireland cavity barriers for a house

Floor level barriers internally along the party wall unless fully filled insulation is installed through the wall and floor zone

**Note:** Cavity barriers at maximum 10m centres, which may be at the corners or in the length. For steps and staggers refer to drawings. For fire stops see page 65.

**For multi occupancy buildings** floor level cavity barriers are required between each dwelling externally and internally. The internal cavity floor barrier can be omitted if the wall cavity is fully filled with mineral wool insulation. Cavity barriers are required around all openings.





## Cavity barriers cont.../



### Cavity barriers checklist

- Cavity barriers installed to provide a cavity tray, or with intumescent cavity barrier strips, allow the cavity moisture to drain. A cavity tray can be integral with the barrier, as in polythene encased cavity barriers
- Barriers should completely close the cavity and be positioned against solid timber members
- Flexible cavity barriers must be a tight fit and the correct thickness of material should be used
- Fix flexible cavity barriers with stainless steel staples at specified spacings
- Rigid cavity barriers must be the exact width. If too small, make up with suitable flexible material
- Protect timber cavity barriers with a DPC between the outside cladding



## **Cavity barriers checklist cont.../**

- At cavity barrier junctions, there should be no gaps between the materials
- Horizontal cavity barriers to be overlapped by the breather membrane above
- The mineral wool in flexible cavity barriers must be tightly butted or lapped by 100mm at each junction





## Cavity barriers and fire stops at party walls

### Party wall junction at external wall

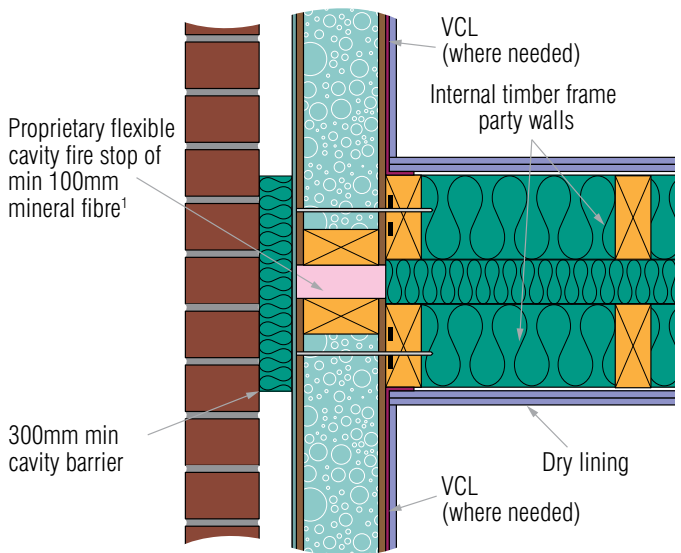

<sup>1</sup>When fully filled insulation is installed after the frame is erected.

**Note:** Plan on party wall junction with external wall - other options available.

See project specifications.

## Party wall to floor junction

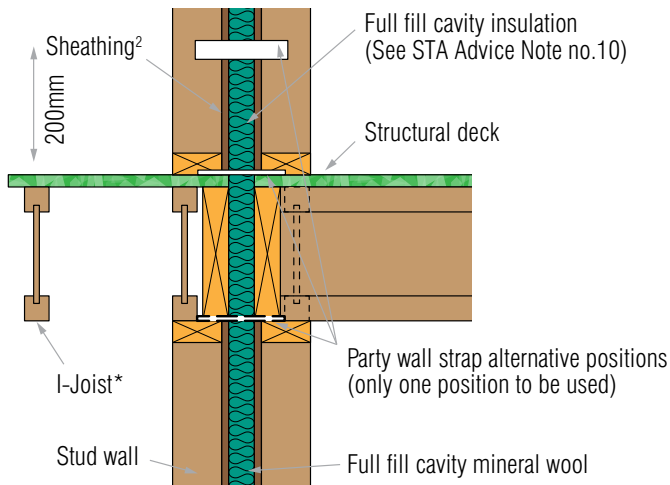

\* I-joist shown, open web or solid timber joists are alternatives



Fire stop to be installed at floor level if wall is not detailed to have a full filled party wall insulation<sup>1</sup>.

<sup>1</sup> Cavity barrier at floor level junction may form part of the fully filled party wall solution.

<sup>2</sup> Fully sheathed party wall shown. Similar details for unsheathed walls.





## Masonry cladding

Masonry cladding should be constructed using a coursing rod to ensure the right levels are achieved at the openings and eaves levels. Pre-plan the coursing to allow for a clearance between window sills, soffits, balcony structures, etc. for differential movement.

Cavity width maintained between the frame assembly and masonry cladding which is typically 50mm by design with an as-built minimum of 40mm and maximum of 60mm or specific design detail. Designer to check with warranty provider.



Before starting to build external masonry walls, plumb down from the eaves and gables of timber frame to check that the cavity widths will fall between the minimum and maximum tolerances. If they do not, then consult and agree actions.

Keep cavities clean and vented. On no account should breather paper, cavity trays or cavity barriers be damaged when cleaning cavities.



## Vented cavity checklist

- Ensure a clear cavity, e.g. clear of mortar droppings
- At base of wall, one brick course below DPC and below sole plate, leave open perpend for vented cavity at maximum 1500mm centres (in Scotland, 1200mm centres, plus have perpend vents at the eaves level)
- Above horizontal cavity trays (e.g. lintels and cavity barriers) open perpend to be at 900mm centres and at least two per lintel

Vented underfloor construction requires clay vents to be built into the masonry - check details and levels on the drawings.

Plastic perpend vents in brickwork are typically for above lintel cavity trays





## Masonry cladding cont.../

To maintain the performance of the building make sure of the following:

- Breather membrane is repaired of any tears and has laps over joints.
- There are no mortar droppings bridging cavities.

Typical clear cavity width a design target of 50mm with as built 40mm minimum and 60mm maximum. Check specification for job specifics.

### Typical section

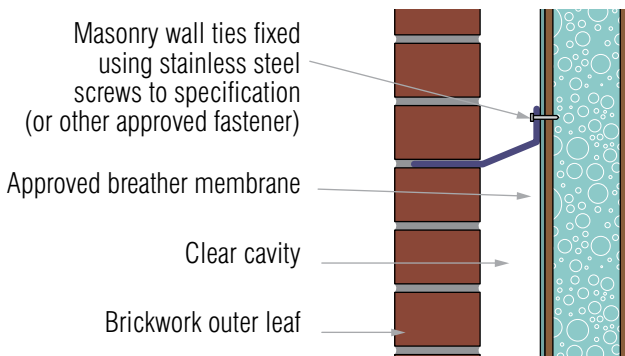



Unlike timber frame stud frame construction, masonry wall ties can be fixed anywhere to the SIP panel, providing the fixings used are appropriate for the SIP board thickness. Wall tie spacing should be specified in the design.

## Typical tie spacings

The figures below are for typical tie spacing at maximum centres. However, the design specification should be checked.

Basic wind speeds less than or equal to 25m/s require 4.4 per m<sup>2</sup>

**Horizontal:** 600mm centres

**Vertical:** 375mm centres

Basic wind speeds greater than 25m/s require 7 per m<sup>2</sup>

**Horizontal:** 600mm centres

**Vertical:** 225mm centres

- Openings at 225mm
- Eaves and verges at 300mm
- Expansion joints at 225mm





### Fixing wall ties

Ensure wall ties are suitable for the cavity width. Wall tie centres and wall tie sizes to the engineer's specification. Make sure they are timber frame wall ties that can accommodate movement; single piece SIP wall tie (pictured below) for up to three stories and above three stories use priority sliding tie.

Do not straighten out pre-bent ties - bend points upwards. Bedded end must be flat against brick.

Drive stainless steel screw (depending on SIP specification) home firmly to outer skin of SIP wall panel or to edge timbers around the openings.

Typically stainless steel flange head screws should be used to provide adequate withdrawal capacity into the SIP (check specification).

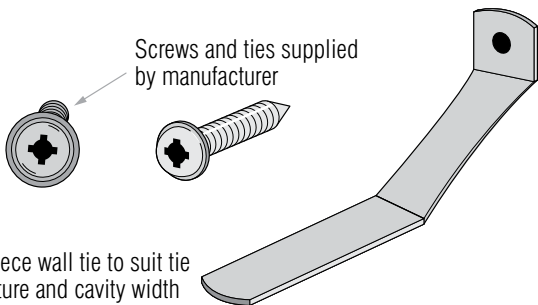



## Supported claddings

Supported claddings such as timber boarding, metal cladding or proprietary render systems should be installed onto vertical treated timber battens or proprietary metal cladding rails fixed on top of the breather membrane to the SIP panels to provide a drained and ventilated cavity.

This cavity should be at least 25mm for render board and 20mm for timber cladding and must incorporate drainage and ventilation gaps at the base equivalent to 500mm<sup>2</sup> per metre at each floor level.

If deeper batten zones are required the battens should be built up in cross layers ensuring that the layer of battens closest to the SIP panel is vertical to prevent moisture traps against the SIP panel.

Battens should be discontinuous across floor zones with a minimum of 10mm gap to allow for differential movement.

### Timber or render board cladding with vertical battens

Supported cladding detail

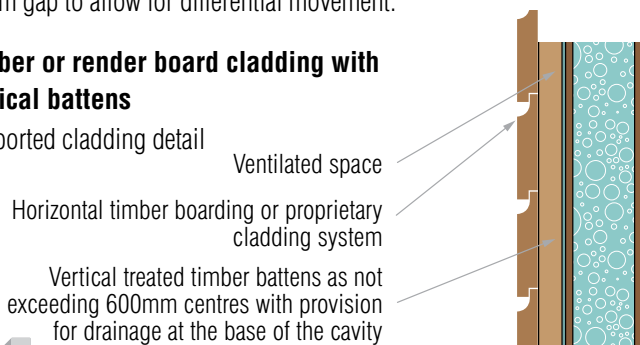



### Cement render carrier board cladding

The use of alternative weather protection other than masonry is becoming common place. There is an advance in new thin coloured render coating systems, which can be applied to SIP frames using a render carrier backing board. The render carrier board shall be third party approved and secured to the SIP panel using vertical treated timber battens. Some third party render boards are suitable for other exterior cladding finishes - such as slip bricks or tiles - for which the principles are the same as for the render finishes given below.

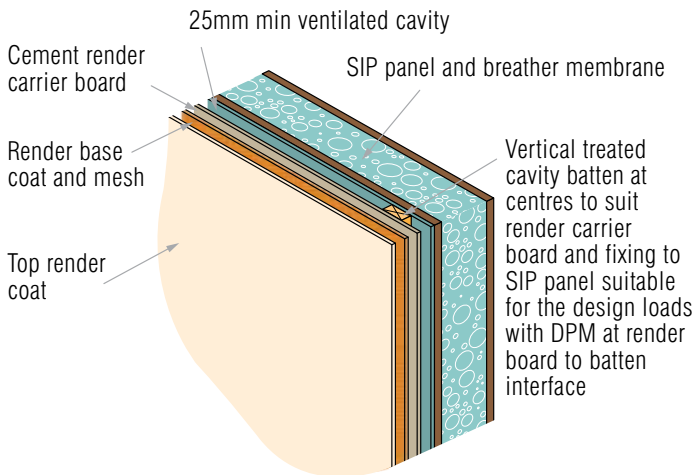

Selection of the cement carrier board is to be based on the compatibility to the render coats being applied and to the third party approval of the board (for example BBA). The board and its fixings are to be suitable for the exposure conditions of the site. The render board company is to provide basic installation instructions compliant with NHBC and LABC standards.

Fixings to cement render boards are typically stainless steel screws specific to the backing board. Screws shall not be overtightened.

The board manufacture will require minimum fixing edge distance for cement boards, which is typically 15mm.

Ensure there is a gap between the boards in accordance with the cement render board details (typically 3-5mm), and that the batten support members are central behind both boards. Boards are typically set out in a checkerboard fashion.

Preservative treated timber battens are advised by the cement render board company and it is good practice to have 60mm wide battens to ensure board to board junctions are supported. A DPM between the batten and cement render board is required unless the render board third party approval body has certified alternative details.





## Supported claddings cont.../

Corrosion resistant fasteners from the cavity batten to the SIP panel are to be specified by the building designer so that they are suitable for both the loads and the SIP outer board thickness capacity.



Movement within frame building at floor levels is a design consideration and advice should be sought from the SIP manufacturer on the movement anticipated. A movement joint should be installed through the render, board and batten. A render detail from the render manufacturer will be required.

Weather detailing around windows, doors and service openings in the cement render cladding are to be provided in accordance with the render company's third party approved details.

Ensure that no vertical joints coincide at window and door corners as this may allow moisture ingress.

Fire rated boards to be provided at boundary conditions to Building Regulation requirements.

## Cement render with expansion joint

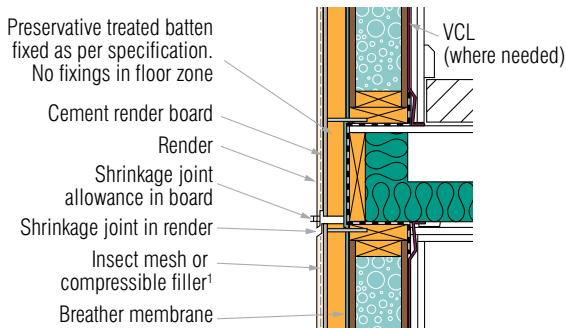

<sup>1</sup>Gap to accommodate filler minimum compressions thickness



Ensure details have been drawn out and have considered movement joints and fixing of battens to the SIP Panel.





## Installing services

### Floor joists

- Only notch or drill solid timber floor joists within specified limits.
- Do not notch I-joists or open web joists.
- Notch solid timber joists to designer's limits.
- Use knockouts for I-joists.
- Refer to manufacturer's recommendations for holes and services in engineered wood joists.

### Walls

- Ensure that studs and rails in load bearing timber frame walls are drilled and notched only when stated on the drawings. No services should be routed through SIP without approval.
- Ensure service points/sockets are fully backed to achieve fire resistance requirements - consult the details.
- For external service penetrations consult the specification for fire stopping and cavity barrier requirements.



## Wall mounted electrical services

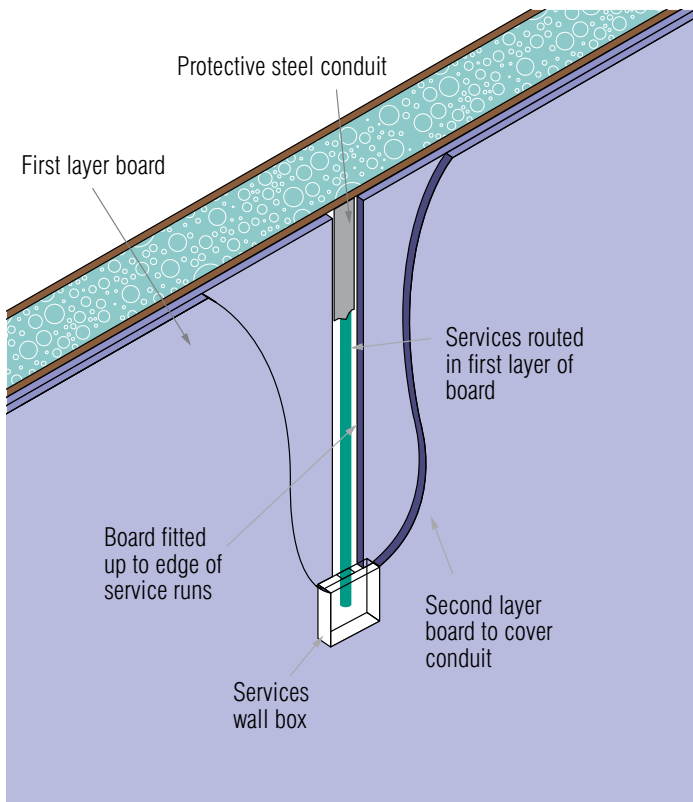



## Installing services cont.../

### Other aspects

- Pipework should be located in a dedicated service void or behind skirtings in external SIP walls and where practical, provide access to pipe bends, stop valves, etc.
- Seal service penetrations of the VCL with PVC tape.
- Use de-rated cabling within the framework, in accordance with IEE guidelines.
- Ensure that surface mounted electrical services in SIP walls are routed in protective steel conduits.

### Pipework behind skirting

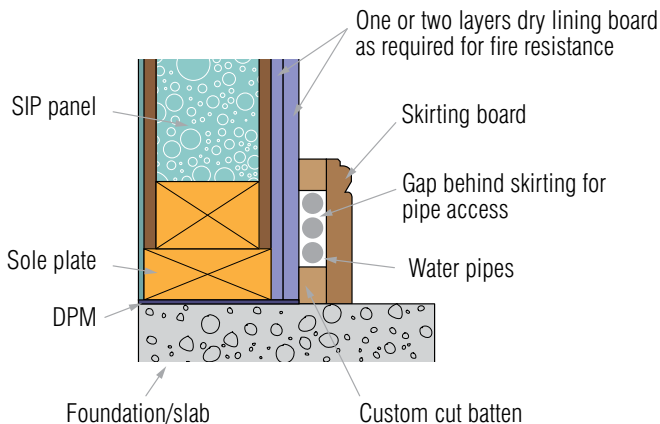

Ensure that the floor-to-wall junctions are correct and that a specification on nailing/screw fixings is available.

Do not overhang floors into the cavity by more than 10mm.

Fix floor and roof members to the specification - ensure SIP roofs are fixed to prevent sliding and uplift. Check that SIP and timber frame walls are correctly built around chimneys and flues. Seek the specification for clearance.

### SIP chimney detail

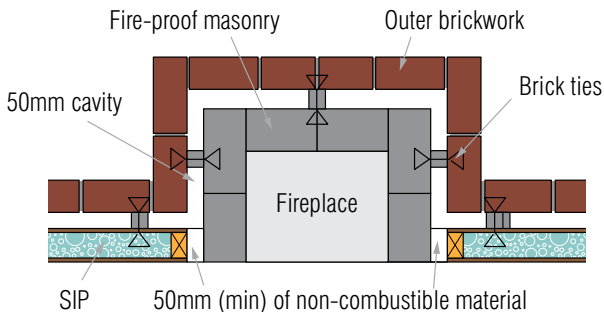



### Flues through SIP roof

Plan of flue

$4d$

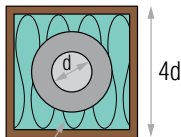

Non-combustible sleeve 'airduct'

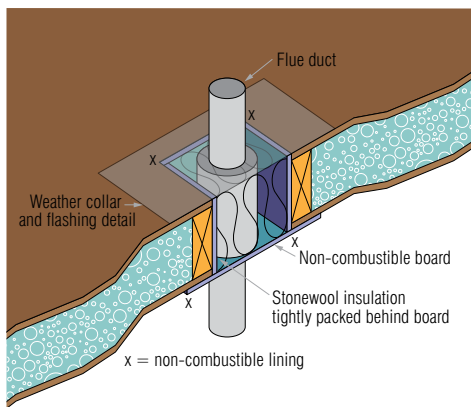

### Flue to combustible material distances

The single skin, un-insulated flue pipe must be at least three times its diameter from combustible materials e.g. a 150mm pipe needs to be a minimum of 450mm from combustible material.

It is possible to use a heat shield to reduce this distance to 1.5 times its diameter, providing the heat shield extends at least 1.5 times the flue's diameter to each side of the flue and there is an air gap of at least 12mm between the shielding material and the combustible material.

A double skin, insulated flue pipe can reduce the clearance required to the combustible materials to 50mm.



## Differential movement

### Why it happens

- Timber is typically installed at maximum 20% moisture content. This reduces to around 10-12% for internal walls in the heated building.
- As timber dries out, its cross-section shrinks and the structure settles.
- Cladding materials also change: clay bricks expand; blocks and calcium silicate bricks shrink - but not in tandem with the timber!
- It is good practice to pre-load the timber frame structure with roof tiles and internal sheeting materials prior to the installation of the masonry cladding, within structural limits.

### The implications

- Any material or component attached to the timber frame structure which overhangs or projects through masonry cladding must have an adequate gap beneath it to allow differential movement to take place without damage to the structure or the cladding.
- Gaps should be filled with a compressible filler, such as an impregnated foam tape.





### **Where allowances needs to be made**

- Window sills.
- Roof verges and eaves.
- Where attached to cladding, e.g. timber or boarding overhangs brickwork.
- Flues and chimneys.
- Any penetrations though the external cladding such as overflow pipes, flues or balcony brackets.
- Traditionally built stair cores.

### **Reducing vertical shrinkage**

- Use I-joists, open web joists or super dried timbers.
- Use of top hung floor to wall detail.
- Ensure detailing is correct to allow for settlement.
- Ensure adequate gaps in supported claddings and linings, plus around penetrations through masonry cladding, are left to take up the downward movement of the frame.
- Keep timbers as dry as possible.
- Where possible minimise the amount of cross-grain material in wall and floor buildups.

## Detailing at window openings

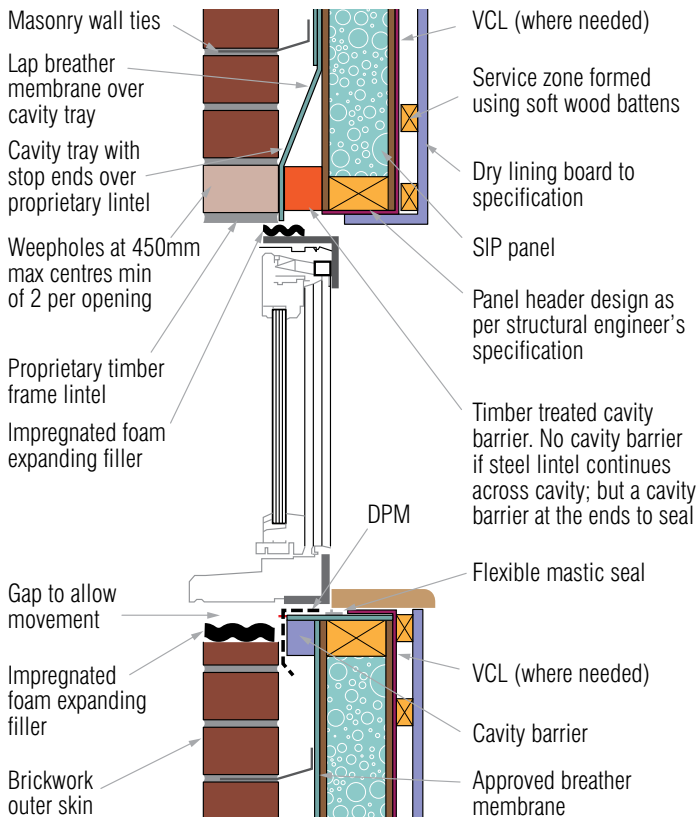



## Differential movement cont.../

Engineered joists, such as open web, super dry timbers and I-joist will reduce movement. The values below relate to platform frame floors. Top hung floors will also reduce movement.

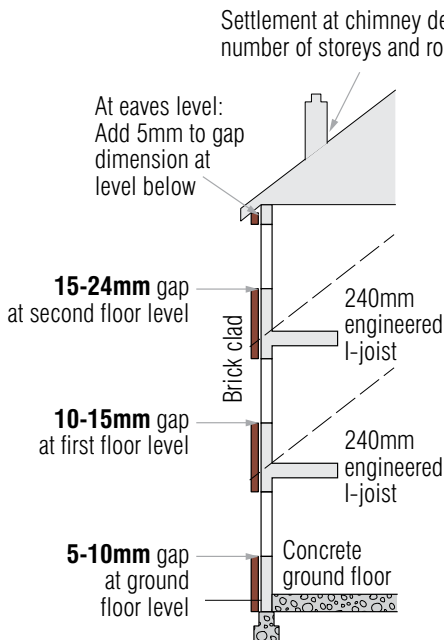

**Note:** The values shown are for generic gaps. They include allowances for brick expansion and filler compression.

The STA member project design specification values can be used in place of these values.

**Note:** values shown are the typical range - adopt maximum values if no information provided.



## Sills

Allow for the differential movement of masonry cladding and the window frame and sill, which is fixed to the SIP.

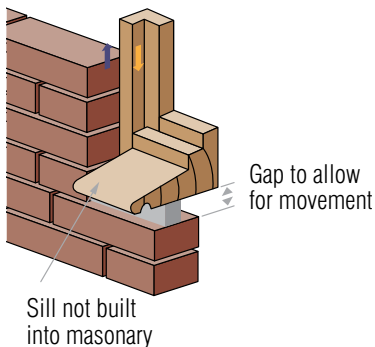

## Verges and eaves

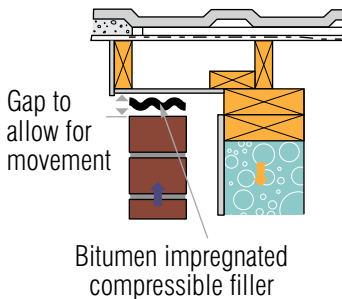
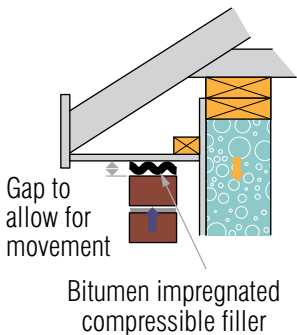

# Summary

For site supervisory staff, the 'golden rule' is attention to detail. Measure, check and check again. Remember that mistakes are more difficult to rectify later. If in doubt, ask.

Take pride in constructing homes and buildings, ensuring generations can enjoy places that are:

- High quality
- Environmentally friendly
- A joy to live in
- Economic to run.



STOP AND ASK.  
DO NOT TAKE RISKS.  
THINK SAFETY.



# Reference documents and further reading

## For the project

- The SIP manufacturer details, drawings and specification.
- The architect's details for all construction details.

## Good practice

NHBC Standards

LABC Warranty Technical Manual

Timber Frame Construction - TRADA

STA - Advice notes on construction and tolerances

STA - Cavity barrier best practice

STA - Erector training books

STA - SIP guidance papers on the website

## Background

There is lots of useful information on airtightness and thermal efficiency within the **'Free resources for housing professionals'** pages of the Energy Saving Trust website:

[www.energysavingtrust.org.uk/organisations/technology](http://www.energysavingtrust.org.uk/organisations/technology)



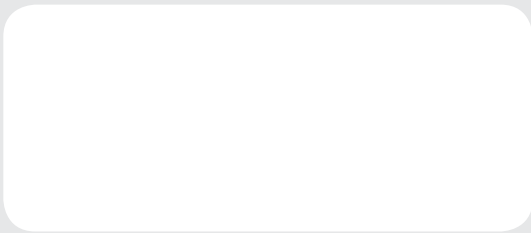

### **1st Edition, 2015**

This guide has been written by Milner Associates for the STA. We hope you find it useful. The management of the STA operates a continuous improvement policy and would therefore be very grateful to receive any review comments for incorporation in the next edition of this pocket book. Thank you.

Whilst the STA has prepared this document to provide guidance on SIP construction, the STA accepts no liability and offers no warranties in relation to it and its contents to the fullest extent applicable law can exclude such liability. Users therefore are required to satisfy themselves as to the suitability of the contents of this guidance for their specific intended purpose.

© STA 2015



## Head office

Structural Timber Association  
The e-Centre  
Cooperage Way  
Alloa  
FK10 3LP

t: 01259 272140  
e: [office@structuraltimber.co.uk](mailto:office@structuraltimber.co.uk)  
w: [www.structuraltimber.co.uk](http://www.structuraltimber.co.uk)